



SIVACON 8PT - Low-voltage switchboard versatile with Safety

Power Distribution Boards and Motor Control Centers SIVACON



The SIVACON 8PT low-voltage switchboard is the solution for buildings and industrial engineering. The wide range of possible module combinations allows the switchboard to be ideally adjusted to meet every demand.

7 Increased safety

The SIVACON 8PT low-voltage switchboard is delivered worldwide exclusively with safety and quality certification for every system verified by type testing.

7 Worldwide deployment

SIVACON 8PT has technology partners all over the world and can be deployed for all applications up to 7400 A – whether fixed-mounted, in plug-in technology or as a withdrawable version.

7 Bundled expertise

Qualified and constantly audited switchgear manufacturers near you offer the bundled expertise from Siemens - fast, flexible and cost-effective.

Highlights

- 7 Safety and quality certification for every system verified by type testing
- 7 High-quality Siemens switchgear guarantees a long service life and reliable operation
- 7 Worldwide presence through local manufacturing by technology partners
- 7 High flexibility and economical solutions

Answers for infrastructure.

SIEMENS

Introduction

Type-tested components for power distribution

Type testing in low-voltage switchgear is increasingly becoming an issue of prime importance worldwide. In future, there will be no other solution.

Siemens is bringing the versatile and type-tested SIVACON lowvoltage switchboard to your door. To this end, Siemens has picked competent, local switchgear manufacturers and has appointed them SIVACON Technology Partners.

SIVACON Technology Partners

These are qualified and permanently audited switchboard panel manufacturers, which Siemens has selected, close to you. This means that you always have the wealth of Siemens know-how at conditions that only a local supplier can offer.

For you, this means: SIVACON including type testing – faster, more flexibly and at lower cost than ever before

Content

7	Introduction	2
7	Overview	4
	Benefits	
	Application	
7	Design	
	- Frame and Enclosure	5
	- Variable Busbar System	6
	- Circuit-Breaker Design	7
	- Withdrawable-Unit Design	8
	- Fixed-Mounted Design	10
	- Reactive Power Compensation	11
	- Cubicle for Customised Solutions	11
7	Type-Tested Switchgear and Controlgear Assembly (TTA)	12
7	Technical Data	13
7	Technology Partner	14

*Versatile with Safety –
Type-Tested Components for Power Distribution*

The SIVACON low-voltage switchboard is the standard solution for building and industrial technology. SIVACON is tailored to the needs of the world market, i.e. it takes into account the call for standard solutions from a single source on the one hand and on the other for local production and the resulting advantages in terms of financing and procurement close to the plant.

As a power distribution board and motor control center, SIVACON is available throughout the world and can be used at all power levels up to 7400 A, as withdrawable as well as plug-in and fixed-mounted units.

Modular Technology

Every SIVACON is made exclusively from standardized and type-coded modules. All modules are of high quality and conform to Siemens design specifications. The multiple possibilities of combining the components fulfill every requirement. The exclusive use of high-quality Siemens switchgear ensures a long service endurance and reliable operation.



Distribution Boards and Motor Control Centers SIVACON

Type-tested power distribution SIVACON 8PT

Overview

- Type-tested standard modules (TTA)
- Standardized busbar position at the top of the cubicle
- 3- and 4-pole busbar system up to 7400 A
- Rated peak withstand current I_{pk} up to 375 kA
- Deep switchgear compartment for universal installation
- Modular structure of device compartments
- Single-front and back-to-back installation
- Cable lead-in from above or below
- Cable connection from the front or rear

Benefits

- Modular technology makes it possible to adapt SIVACON optimally to all requirements:
- Standard horizontal busbar position at the top of the cubicle
- Any components can be installed in the device compartments regardless of the busbar position and cubicle depth
- Requirement-oriented compartmentalization of functional units (Form 1 to Form 4 according to IEC 60439-1)
- Deep device compartments optimum adaptation to space conditions
- Wall-mounted or free-standing
- Cables and busbars may be connected optionally from above or below
- Cabling compartments front- or rear-located good accessibility of busbars

Application

- SIVACON for all applications in the low-voltage network

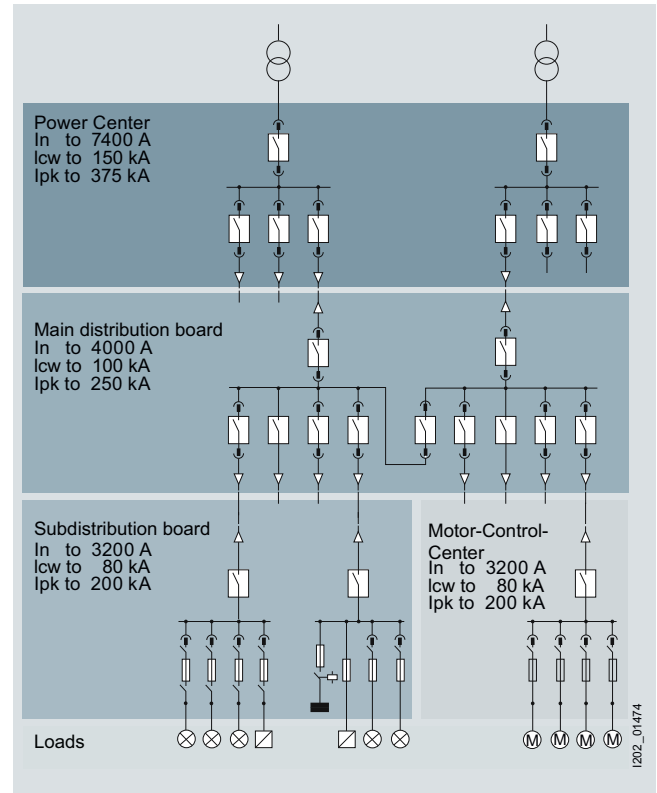

Cubicle Dimensions/Cubicle Structure

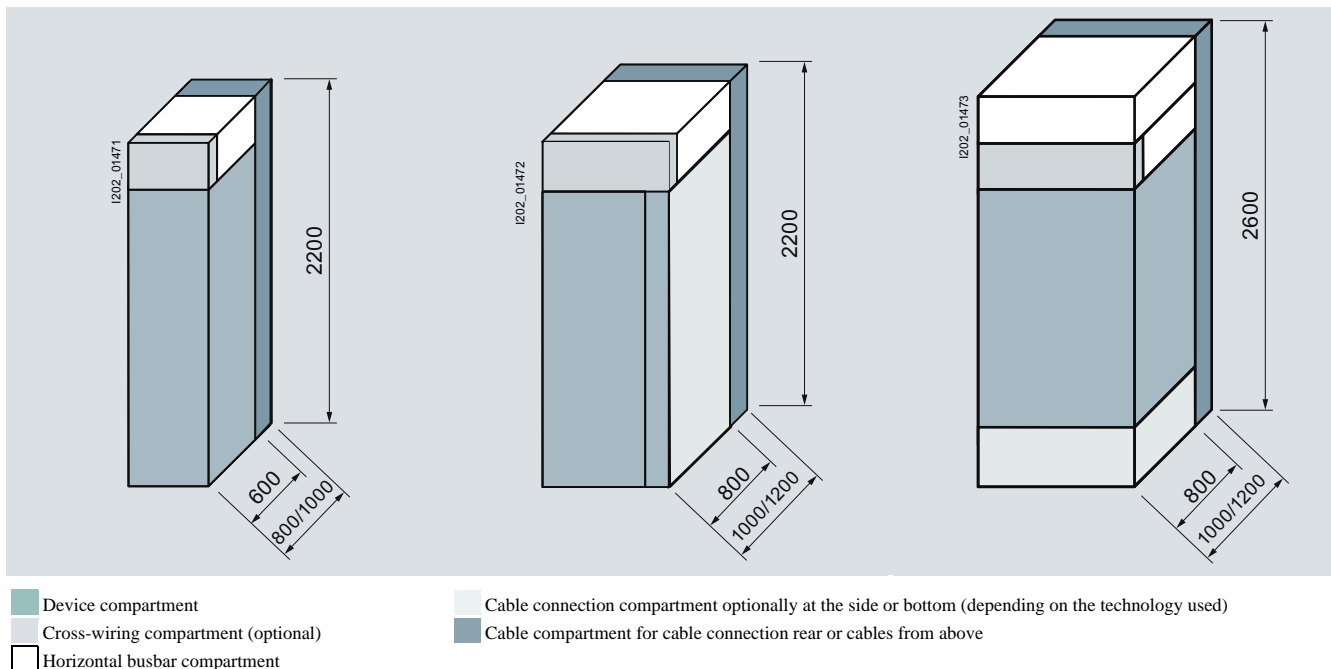

Design

Frame and Enclosure

The frame consists of rigid sheet steel sections that are linked to one another:
SIVACON's dimensionally accurate and sturdy frame is available in bolted or welded versions.

Benefits:

- All-round perforation rows with a 25-mm hole grid for individual installation
- Flexible door system for all requirements
- Door opening angle up to 180°
- Spring-loaded locks reliably prevent doors from opening unintentionally
- Pressure-relief top covers

Surface Treatment:

- Optionally powder-coated, wetpainted or sendzimir-galvanized

Material

Frame and enclosure are manufactured from sheet steel in the following thicknesses:

Frame: 2.5 mm
Enclosure: 2.0 mm

Degrees of Protection to IEC 60529

IP 30, IP 31, IP 40, IP41, IP 42 naturally ventilated
IP 40, IP 54 unventilated



Frame and Enclosure

Cubicle Dimensions (Without Enclosure):

	Cubicle height mm	Cubicle width mm	Cubicle depth mm
	2000	400, 600, 800, 850, 1000, 1200	600, 800, 1000, 1200
	2600 (with busbar top unit)		

Variable Busbar System

Differing requirements for the busbar system call for individual options. SIVACON offers modules for economical setup and high level of safety.

Benefits:

- Busbar position at top
- Busbar system for rated currents up to 7400 A
- User-oriented gradation of rated currents
- Rated peak withstand current I_{pk} up to 375 kA
- Separation of the busbar compartment from the device compartment
- Transport unit joints easily accessible from above
- Arc barriers for limiting the effects of the arcing fault



Variable Busbar System

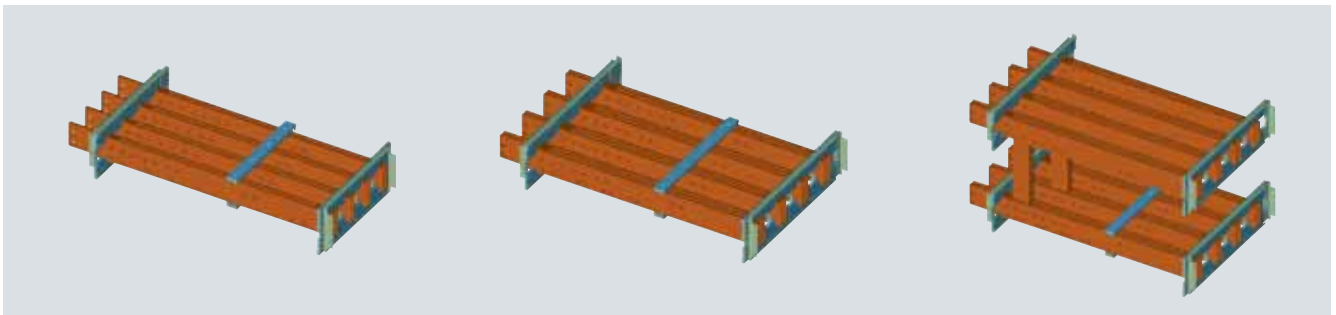

up to 3200 A

up to 4000 A

up to 7400 A

Busbar System

Circuit-Breaker Design

The supply, feeder and coupling cubicles of the circuit-breaker design are equipped with withdrawable or fixed-mounted 3W air circuit breakers (ACB).

As a large number of loads are generally connected to these cubicles, particular importance is attached to them in terms of the long-term operating reliability and personal safety of the switchboard.

SIVACON meets these requirements with circuit-breaker design components.

Compact and Reliable:

- High degree of safety due to type-tested standard modules (TTA)
- Test and disconnected positions with door closed
- Circuit breakers integrated in separate compartments, each equipped with a separate door
- Optimum connection conditions for every rated current range
- Cable connection from above or below

User-Friendly with 3W

Siemens 3W fixed-mounted and withdrawable air circuit breakers are used for the rated current range from 630 to 6300 A. This means:

- Free choice of the supply direction without any restrictions in terms of technical data
- High short-time current-carrying capacity for time-graded short-circuit protection up to 400 ms assures reliable operation of sections of the switchboard not affected by a short-circuit
- Short-circuit protection with short-time grading control (ZSS) for very brief delay times (50 ms), irrespective of the grading level
- LCD operating current indication in the control console (without ammeters and current transformers)
- Indication and operation when the door is closed



Reliable travel of the circuit breaker while the door is closed



Circuit breaker design

Switching Device Compartment

- Reliable travel of the circuit breaker while the door is closed
- A maintenance position allows direct local inspection without removal of the circuit breaker

Cable or Busbar Connection Compartment

- Cable or busbar connection optionally from above or below
- A rated current-dependent connection compartment offers optimum termination conditions for cables and busbars
- Assembly times are shortened by optimum connection compartments



Optimum connection compartments for high safety

Withdrawable-Unit Design

Cubicles for motor and cable feeders in withdrawable-unit design offer highest operating comfort with optimum safety and availability. By virtue of the guiding withdrawable principle easy and rapid changes or adaptations are possible.

Thus individual modules can be e.g. supplemented or exchanged. Even compartments may be converted during operation. The withdrawable-unit design of SIVACON for highest possible



withdrawable-mounted

Withdrawable Dimensions/Cubicle Structure

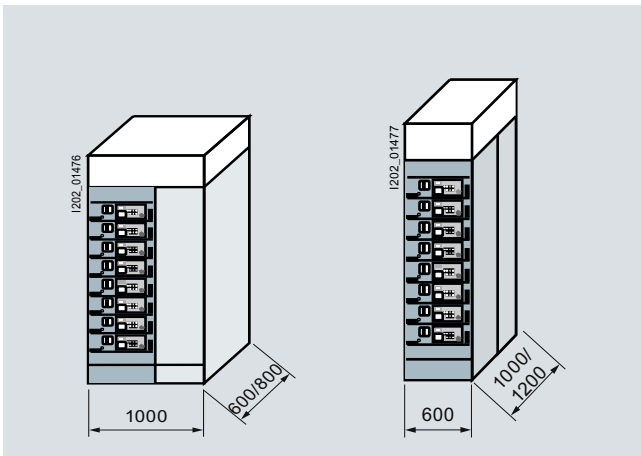

Cable connection right-hand side

Cable connection rear

Benefits

- Outgoing feeders up to 250 kW Non-fused and fused protection
- Test and disconnected position with protection degree IP 30
- Standard operator interface for all withdrawable-units
- Isolating gaps on the supply and feeder sides
- Space-saving sizes of withdrawableunits from 100 mm minimum module height.
- Cable connection compartment at front or rear
- Easy adaptation to changing operating conditions without shutdown of switch board

SIVACON withdrawable-units - operating and handling safety

- Standardized design in eight modularunit heights (100, 150, 200, 300, 400, 500, 600, 700 mm)
- Clearly visible withdrawable-unit positions (connected, test and disconnected position)
- Integrated maloperation protection in all withdrawable-units
- Control plugs up to 40-pole and additional bus contacts (optional)
- Hinged front panel of withdrawable-units for adjustments (unit height 200 mm)
- Insertion support for easy moving of the withdrawable-units > 250 A
- Plenty of space for auxiliary equipment by possibility of fitting components at the rear
- Lockable disconnected position for safe working at the consumer



Hinged front panel of withdrawable-units

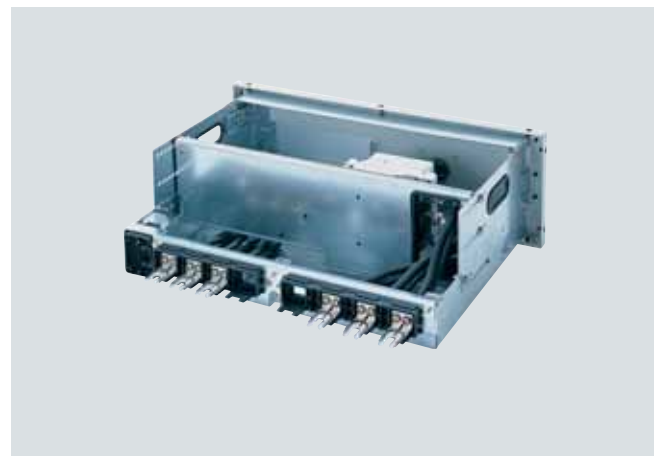

Rear view of withdrawable-unit module height 200 mm.

Withdrawable-units offer

- Standardized design in eight modular unit heights (100, 150, 200, 300, 400, 500, 600, 700 mm)
- Clearly visible withdrawable-unit positions (connected, test and disconnected position)
- Integrated maloperation protection in all withdrawable-units
- Control plugs up to 40-pole and additional bus contacts (optional)
- Hinged front panel of withdrawable-units for adjustments (unit height ≥ 200 mm)
- Insertion support for easy moving of the withdrawable-units > 250 A
- Plenty of space for auxiliary equipment by possibility of fitting components at the rear
- Lockable disconnected position for safe working at the consumer

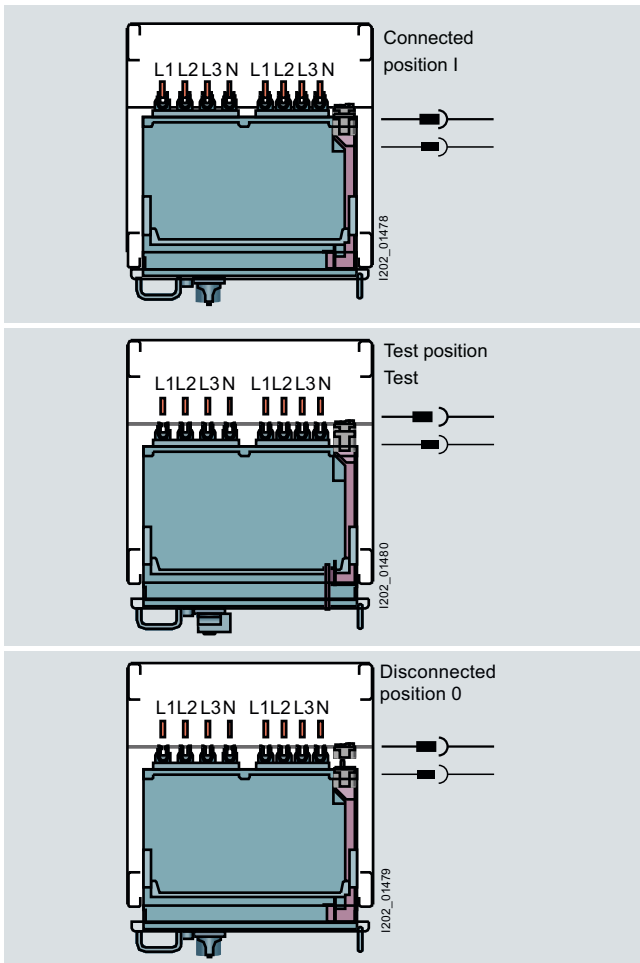

Plug-on bus system

The plug-on bus system is located at the rear of the cubicle. It offers safe-to-touch protection without additional shutters to live parts.

Integrated protection against electric shock

- 3- and 4-pole versions
- Safe-to-touch (IP 20 B)
- ap openings in a modular grid of 25 mm



Plug-on bus system with safe-to-touch protection

Versatility and reliability with adaption to changing requirements

- Simple conversion of withdrawable-unit compartments without shut-down of switch board
- No connection work necessary inside withdrawable-unit compartment
- Connections for power and control cables in a separated cable connection compartment
- Cable connection compartment optionally 400 mm wide (front) or 600 mm wide (rear)



Cable connection front and rear

Fixed-Mounted Design

The cubicles for cable feeders in fixed-mounted execution are equipped with molded-case circuit breakers or fuseswitch disconnectors, depending on requirements.

These cubicles are used for applications in which replacement under operating conditions is not necessary or where short downtimes are acceptable.

In this case, the SIVACON fixed-mounted design offers excellent economy, safety and variability.

Cable feeders in compartment design

The compartment design with its individual sub-section for every circuit breaker offers increased active safety for installation and personnel protection.

- Individual sub-sections with doors for each circuit breaker
- Circuit breaker 3VL with or without plug-in socket
- High form of internal separation up to Form 4 Type 7 acc. to BS EN 60439 (gland box per functional unit)
- Optimum connection conditions in the rear cable connection compartment



Cable connection compartment at the rear with one cable gland box per functional unit, internal separation Form 4 Type 7 acc. to BS EN 60439



Cable feeders in compartment design

Cubicle Dimensions/Cubicle Structure

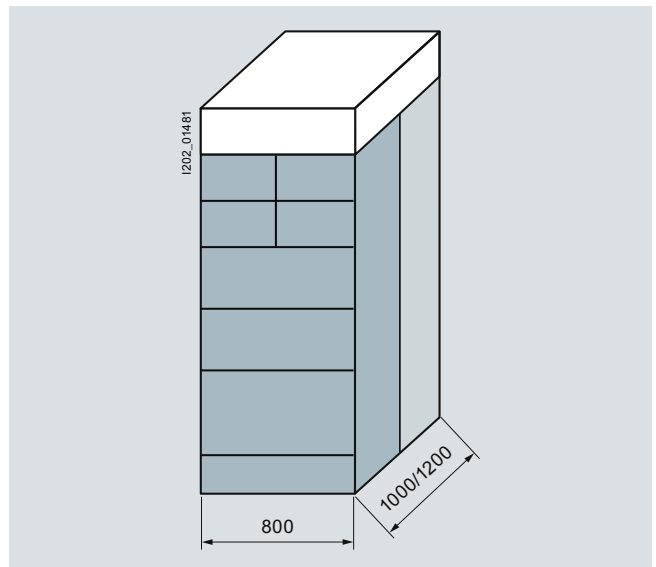

Cubicle Dimensions/Cubicle Structure Circuit breaker 3RV / 3VL, cable connection rear, up to 630 A/feeder

Reactive Power Compensation

The cubicles for central reactive power compensation ease the load on transformers and cables, reduce transmission losses and save current costs. Depending on the load structure, they are equipped with chokeless or choked capacitor modules.

Controller Module with Electronic Power Factor Controller for Flush Door Mounting

- Multifunction display
- Self-adaption of the C/k value
- Adjustable nominal cos phi from 0.8 ind to 0.98 cap
- Manual/automatic operation

Capacitor Module up to 100 kvar

- Fuse-switch disconnectors
- Capacitor contactors
- MKK power capacitors
- Discharging units
- Filter circuit chokes

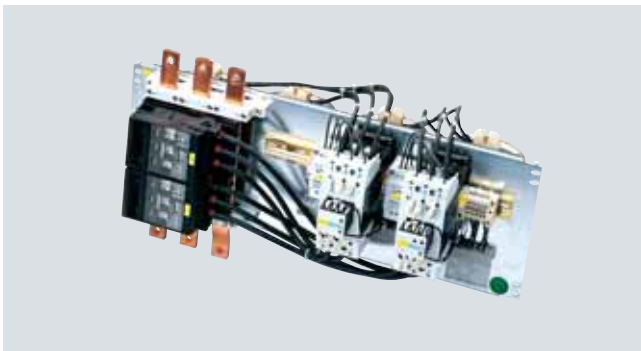

Capacitor module, 100 kvar (chokeless)

Cubicle for Customised Solutions

Various installation components are available for customised solutions, e.g. for open and closed-loop control tasks.

- 3- and 4-pole vertical distribution busbars
- Rated currents up to 1200 A
- Rated short-time withstand current up to Icw 65 kA
- Cubicle-length doors or compartment doors
- Compartmentalization
- Various installation components

Cubicle Dimensions/Cubicle Structure

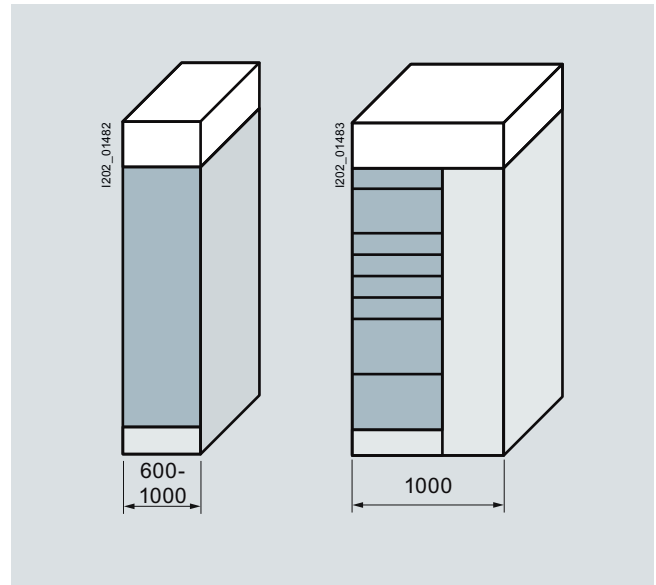

Cubicle for customised solutions up to 1200 A



Cubicles for central reactive power compensation



Cubicle for customised solutions

Type-Tested Switchgear and Controlgear Assembly (TTA)

SIVACON is a type-tested switchgear and controlgear assembly (TTA) whose physical characteristics were designed in the test laboratory both for normal operating conditions and for fault situations. Conclusive type tests assure a maximum of reliability and personal safety. SIVACON has passed the following verification tests as detailed in IEC 60439-1, DIN EN 60439-1 (VDE 0660 Part 500).

Type Testing:

- Verification of temperature rise limits by test
- Verification of dielectric properties by test
- Verification of the short-circuit withstand strength by test
- Verification of the effective connection between the exposed conductive parts of the assembly and the protective circuit by inspection or resistance measurement
- Verification of the short-circuit withstand strength of the protective circuit by test
- Verification of clearances and creepage distances
- Verification of mechanical operation
- Verification of the degree of protection

Every SIVACON Switchboard Undergoes Routine Testing Before Delivery:

- Inspection of the assembly including wiring and, if necessary, electrical operation test
- Dielectric test
- Checking of protective measures and of the electrical continuity of the protective circuits

These Safety Requirements are Supported by a Series of Details in SIVACON, for Example:

- With the withdrawable circuitbreaker design, operating errors are ruled out by exactly shaped mechanical guides and interlocks
- Only a few, exclusively high-quality insulating materials are used (e.g. for busbar supports, reinforcements, etc.)
- Use of high-quality Siemens switchgear ensures long lifetime and minimized downtimes
- Reliable disconnection after 70 to 100 ms, even at long-time delays by 3W circuit breakers with short-time grading control (ZSS)
- Computer-assisted configuring ensures error-free selection and arrangement of items
- Arcing fault-tested
- Effective quality management



Technical specifications

Standards and specifications	Type-tested low-voltage switchgear and control gear assembly (TTA) Testing of response to internal faults (arcing faults)	IEC 60439-1, DIN EN 60439-1 (VDE 0660 Part 500) IEC 61641, VDE 0660 Part 500, Supplement 2	
Creepage distances and clearances	Rated impulse withstand voltage (U_{imp}) Overvoltage category Pollution degree	8 kV III 3	
Rated insulation voltage (U_i)		1000 V	
Rated operational voltage (U_e)		690 V	
Rated currents (I_n) Busbars (3-pole and 4-pole)	Main horizontal busbars	Rated current Rated peak withstand current (I_{pk}) Rated short-time withstand current (I_{cw})	≤ 7400 A ≤ 375 kA ≤ 150 kA, 1 s ≤ 120 kA, 3 s
	Vertical busbars for circuit breakers	Rated current Rated peak withstand current (I_{pk}) Rated short-time withstand current (I_{cw})	≤ 6300 A ≤ 250 kA ≤ 100 kA, 1 s ≤ 80 kA, 3 s
	Vertical busbars for fixed-mounted design	Rated current Rated peak withstand current (I_{pk}) Rated short-time withstand current (I_{cw})	≤ 1400 A ≤ 163 kA ≤ 65 kA*, 1 s ≤ 50 kA, 3 s
	Vertical busbars for withdrawable-unit design	Rated current Rated peak withstand current (I_{pk}) Rated short-time withstand current (I_{cw})	≤ 1200 A ≤ 163 kA ≤ 65 kA*, 1 s ≤ 50 kA, 3 s
Switchgear rated currents		Circuit breakers Outgoing feeders	≤ 6300 A ≤ 630 A
Internal separation	Form 1 to Form 4	IEC 60439-1, Section 7.7, DIN EN 60439-1	
Surface treatment	Frame parts Enclosure Doors	Galvanized/powder-coated/wet-painted Galvanized/powder-coated/wet-painted Powder-coated/wet-painted	
Degree of protection	To IEC 60529, EN 60529	IP 30 to IP 54	
Dimensions		Height: 2200, 2600 mm (with busbar top unit) Width: 400, 600, 800, 1000, 1200 mm Depth: 600, 800, 1000, 1200 mm	

* Rated conditional short-circuit current $I_{cc} \leq 100$ kA

The information provided in this brochure contains descriptions or characteristics of performance which in case of actual use do not always apply as described or which may change as a result of further development of the products. An obligation to provide the respective characteristics shall only exist if expressly agreed in the terms of contract. Availability and technical specifications are subject to change without notice. All product designations may be registered trademarks or product names of Siemens AG or supplier companies whose use by third parties for their own purposes may violate the rights of the owner.

© Siemens AG 2010 • Order No.: E10003-E38-10T-G2201-7600 • PI 0110 2. DB En

Siemens AG
Industry Sector
Building Technologies Division
Postfach 10 09 53
93009 REGENSBURG
GERMANY

www.siemens.com/sivacon

SIVACON

Technology
Partner

SIEMENS



PT SEMACOM INTEGRATED
Type-tested MV & LV Switchboard Manufacturer

www.semacom-integrated.com

OFFICE & FACTORY

Jl. Intan I RT 001/001, Kp. Poncol, Ds. Curug, Kec. Gunung Sindur, Bogor 16340, Jawa Barat
Tel: +62-251-861 5872 / 73 Fax : +62-251-861 5874 E-mail: info@semacom-integrated.com

SALES OFFICE

Ruko Golden Boulevard Blok F1 No. 16, Jl. Pahlawan Seribu, BSD City, Tangerang Selatan 15323, Banten
Tel: +62-21-5316 0906 (hunting) Fax : +62-21-5316 0907 E-mail: sales@semacom-integrated.com

